

NOVADRY

ND65/ND100/ND160/ ND200

Operating instructions 300791606_002_C2

Part Numbers

111065N...

111100N...

111160N...

111200N...



Copyright notice

©Leybold GmbH. All rights reserved.

Trademark credit

Leybold and the Leybold logo are trademarks of Leybold GmbH, Bonner Strasse 498, D-50968 Cologne.

Disclaimer

The content of this manual may change from time to time without notice. We accept no liability for any errors that may appear in this manual nor do we make any expressed or implied warranties regarding the content. As far as practical we have ensured that the products have been designed and constructed to be safe and without risks when properly installed and used in accordance with their operating instructions.

We accept no liability for loss of profit, loss of market or any other indirect or consequential loss whatsoever.

Product warranty and limit of liability are dealt with in our standard terms and conditions of sale or negotiated contract under which this document is supplied.

You must use this product as described in this manual. Read the manual before you install, operate, or maintain the product.

Contents

1 Safety and compliance.	6
1.1 Definition of Warnings and Cautions.	6
2 Important Safety Information.	7
2.1 Mechanical hazards.	7
2.2 Electrical hazards.	7
2.3 Thermal hazards.	8
2.4 Hazards caused by materials and substances.	8
2.5 Noise hazard.	8
2.6 Risk of damaging the pump.	8
3 Description.	10
3.1 Supplied equipment.	10
3.2 Technical data.	10
3.3 Accessories.	11
4 Transport and storage.	13
5 Installation.	14
5.1 Placement.	14
5.2 Conforming use.	15
5.2.1 Non-conforming use.	15
5.3 Connect the pump.	15
5.4 Electrical connection.	16
5.5 Soft starter.	16
5.6 Optional VFD use.	17
5.7 Gas ballast.	17
5.8 Gas ballast configuration.	17
6 Operation.	18
6.1 Switching off.	18
7 Maintenance.	19
7.1 Maintenance schedule.	19
7.2 Tools required for maintenance.	19
7.3 Pump timing belt change.	20
7.4 Replace the belt.	20

Contents

7.4.1	Disassemble drive enclosure.	20
7.4.2	Disassemble rotor disc, screw and fan.	21
7.4.3	Disassemble belt chamber cover.	21
7.4.4	Disassemble fail safe gears.	22
7.4.5	Disassemble belt.	23
7.4.6	Assemble tooth belt.	24
7.4.7	Assemble motor screw.	24
7.4.8	Assemble fail safe gear.	25
7.4.9	Assemble belt chamber cover.	26
7.4.10	Assemble fan.	27
7.4.11	Assemble drive enclosure.	27
7.4.12	Electric connection.	27
7.4.13	Verify motor rotation.	28
7.5	Blow off valve cleaning.	29
7.6	Replace electrical motor.	30
7.6.1	Motor disassembly.	30
7.6.2	Motor assembly.	34
7.7	Motor part list.	38
8	Troubleshooting.	39
9	Disposal.	43
9.1	Waste disposal.	43
10	Leybold Service.	44

List of Figures

Figure 1. Dimensional drawing, dimensions in mm.	11
Figure 2. Correct lifting of pump.	13
Figure 3. Connections and controls.	14
Figure 4. Arrow - direction of rotation.	16
Figure 5. Gas ballast configuration.	17
Figure 6. Tools required for maintenance.	19
Figure 7. Blow Off Valve Cleaning.	30

Safety and compliance

1 Safety and compliance

1.1 Definition of Warnings and Cautions

NOTICE:

Obligation to Provide Information

Read and follow these instructions carefully before installing and commissioning to ensure optimum and safe operation right from the start.



Safe and proper operation is guaranteed when used correctly and in accordance with the instructions contained in these operating instructions. Please read all safety instructions in this section and the rest of this manual carefully and make sure that these instructions are followed. The device may be operated and maintained only by trained personnel in the proper condition and as described in the operating instructions. Also observe local and state requirements and regulations. If you have any questions regarding safety, operation or maintenance of the device, please contact our nearest subsidiary.



DANGER:

Danger indicates a hazard with a high level of risk which, if not avoided, will result in death or serious injury.



WARNING:

Warning indicates a hazard with a medium level of risk which, if not avoided, could result in death or serious injury.



CAUTION:

Caution indicates a hazard with a low level of risk which, if not avoided, could result in minor or moderate injury.



NOTICE:

Information about properties or instructions for an action which, if ignored, will cause damage to the pump or the system.

We reserve the right to change the design and the stated data. The illustrations are not binding.

Keep the instructions for future use.

Important Safety Information

2 Important Safety Information

Pressures given in bar or mbar are absolute values. If exceptionally a gauge pressure is meant, a "g" is added (for example, bar (g)).

2.1 Mechanical hazards



WARNING:

When rotated in the wrong direction, the pump will generate up to 4.5bar (g) pressure at the inlet. If a vacuum system is connected, the pressure build up can lead to explosion of the system.

1. Avoid exposing any part of the human body to the vacuum.
2. Select a secure place for the appliance (level surface).
3. Never operate the pump without a connected intake line or without fitting a blank flange.
4. The discharge port of the pump must not be blocked or constricted. Never operate the pump with a seal-off stopper in place blanking off the exhaust port. Operate the pump only with a connected vacuum system to the intake flange.
5. With a closed exhaust pipe, the pump can generate up to 4.5 bar (g) overpressure on the exhaust. The exhaust pipes should be laid out accordingly.
6. Condensates from the pump can collect inside or at the exhaust, escape and spill onto the floor, when operating the pump without an exhaust line or during transport with an exhaust being not blanked off. In this case there exists the risk of slipping.
7. Take note of the labelling of inlet and outlet. A mix-up can lead to dangerous build-up of pressure in the vacuum system or in the system. After each change of the electrical connection, check the pump's rotational direction.
8. In case of power supply outage, the vacuum system is ventilated by the pump. If this is not wanted, install a non-return valve at the inlet.
9. After a loss of power, the pump restarts independently. If this is not wanted, install a restart inhibitor.
10. Do not operate the pump with any of the covers removed. This may result in serious injury.

2.2 Electrical hazards



DANGER:

After a mains power failure the pump will run up automatically again. This also applies in the case of an emergency shut-down. In order to prevent the pump from running up automatically again, the pump must be integrated within a control arrangement such that it can only be switched on manually again after the mains power has returned.

1. Never connect the pump to mains power when the motor junction box is not closed correctly.
2. The electrical connection must only be provided by a trained person.

Important Safety Information

3. Obey the national regulations in the country of use like EN 50110-1 for Europe.
4. Note the information on the IP type of protection.

2.3 Thermal hazards



CAUTION:

The surface of the pump may attain temperatures over 80 °C. There is the risk of burn injury.

-
1. Before servicing and maintenance work, always leave the pump to cool down.

2.4 Hazards caused by materials and substances



DANGER:

Before commissioning the pump, make sure that the media which are to be pumped are compatible with each other so as to avoid hazardous situations. Observe the instructions for proper and improper use of the pump in Conforming Use.

2.5 Noise hazard



CAUTION:

The noise level of the pump during ultimate pressure operation corresponds to the values stated in the technical data. In other operating modes and depending on the connected vacuum system, higher values can be expected. Make sure that suitable protection measures are taken to protect your hearing.

2.6 Risk of damaging the pump

-
1. Before starting up for the first time, the motor circuit must be equipped with a suitable protective motor switch. Please take note of the information in these Operating Instructions and on the electric motor (wiring diagram).
 2. Do not allow the ingestion of objects (screws, nuts, washers, pieces of wire, etc.) through the inlet port. If required, use an inlet filter.
 3. Do not use the pump for applications that produce abrasive or adhesive powder vapour sales or service department for advice.
 4. This pump is suited for pumping water vapour within the specified water vapour tolerance limits.
 5. Avoid vapour that can condense into liquids when being compressed inside the pump, if these substances exceed the vapour tolerance of the pump.
 6. In the case of wet processes we recommend the installation of liquid separators upstream and downstream of the pump as well as the use of the gas ballast.
 7. The exhaust line should be laid so that it slopes down and away from the pump so as to prevent condensate from back streaming into the pump.
 8. Avoid the entry of particles and fluids.

Important Safety Information

9. The air intakes of the pump and the motor must remain free.

Description

3 Description

The pump is a dry-compressing vacuum pump and can evacuate containers in the rough vacuum range.

The pump is connected to a 3-phase network on the motor terminal board and operated directly from the mains. It is air-cooled and requires minimum maintenance.

3.1 Supplied equipment

The pump is delivered ready for operation. Intake and exhaust flanges are covered with caps.

3.2 Technical data

Table 1 Technical data

NOVADRY	65	100	160	200
Maximum pumping speed without gas ballast	65 m ³ /h	105 m ³ /h	150 m ³ /h	200 m ³ /h
Ultimate pressure without gas ballast	0.1 mbar			
Maximum permissible inlet pressure	1200 mbar			
Maximum permissible discharge pressure (Relative to ambient) ⁵⁾	200 mbar			
Water vapour tolerance with gas ballast ⁴⁾	60 mbar			
Water vapour capacity with gas ballast ⁴⁾	1.9 kg/h	2.9 kg/h	5.2 kg/h	6.9 kg/h
Permissible ambient temperature	0 to +40 °C			
Storage temperature	-20 to +60 °C			
Noise level without external silencer, at ultimate pressure (according to DIN EN ISO 2151)				
▪ 50 Hz versions	67 dB(A)		70 dB(A)	
▪ 60 Hz versions	70 dB(A)		73 dB(A)	
Relative ambient atmospheric humidity	95%, non-condensing			
Maximum Installation height ¹⁾	Up to 1000 m above sea level			
Cooling	Air			
Mains voltage 50 Hz versions ²⁾	400 V ± 10% or 200 V ± 10%			
Mains voltage 60 Hz versions ²⁾	460 V ± 10% or 230 V ± 10% or 200/380 V ± 10% , 3 ph			
Phases	3-ph			
Maximum current 50 Hz versions 200/400 V ³⁾	6.4/3.2 A	8.6/4.3 A	13.0/6.7 A	15.5/7.5 A
Maximum current 60 Hz versions 230/460 V ³⁾	5.6/2.8 A	7.6/3.8 A	11.3/5.7 A	13.7/6.5 A
Maximum current 60 Hz versions 200/380 V ³⁾	6.0/3.4 A	8.3/4.6 A	12.8/6.9 A	15.5/8.9 A
Permissible motor speed ²⁾	50/60 Hz			
Protection class	IP 55			
Intake connection	G 2"			
Discharge flange DN	G 1 1/2"			
Weight (approximate)	85 kg	95 kg	105 kg	115 kg

1) Please inquire for installation heights above 1000 m.

Description

- 2) Depending on version 50 or 60 Hz. See the pump nameplate.
- 3) Motor protective switch must be suitable for operation with IE3 motors.
- 4) Depending on installed configuration. See [Gas ballast configuration](#) on page 17 for details.
- 5) Up to 200 mbar possible depending on the inlet pressure of the pump. With higher outlet pressure, the ultimate pressure will be higher.

Figure 1. Dimensional drawing, dimensions in mm

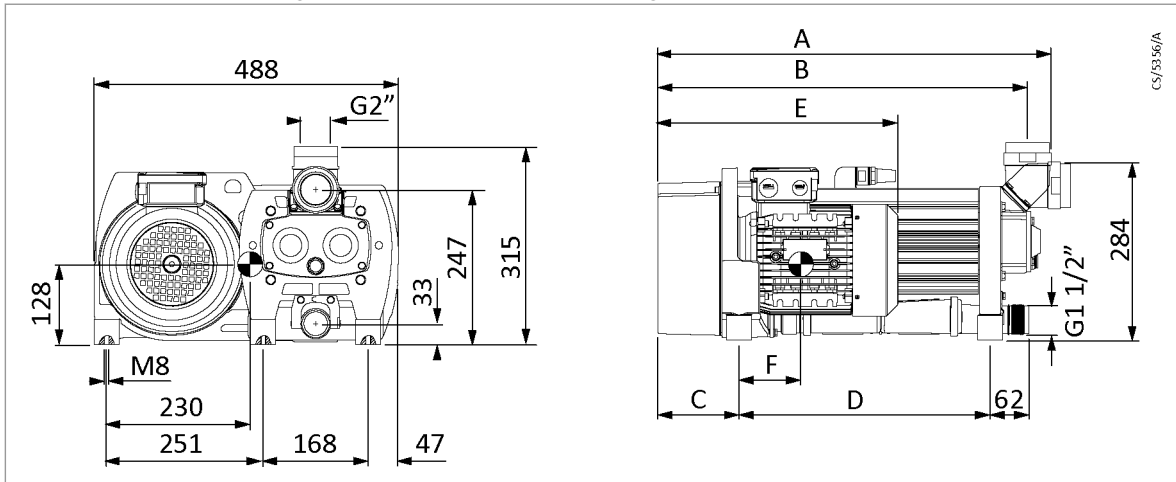

Variable dimensions	ND65	ND100	ND160	ND200
A	630	722	875	875
B	592	684	837	837
C	130	130	174	174
D	402	494	647	647
E	385	385	405	424
F	99	139	219	219

3.3 Accessories

Table 2 Accessories

Centering ring, aluminium, FPM DN 40 ISO-KF	18208
Clamping ring, aluminium DN 40 ISO-KF	18343
Inlet adapter G 1¼"	111005A21
Inlet adapter DN40 ISO-KF	111005A20
Inlet adapter DN63 ISO-K	111005A24
Exhaust adapter DN40 ISO-KF	111005A30
Exhaust adapter G 1½"	111005A32
Replacement timing belt 50 Hz versions	EK6528531
Replacement timing belt 60 Hz versions	EK6528533
Belt replacement tool kit	EK6530942
Pump flushing kit	111005A00
Inlet non return valve (for operation > 10 mbar)	111005A15
Inlet adapter NPT 1¼ - 11.5	111005A22
Inlet adapter NPT 2 - 11.5	111005A23
Exhaust adapter NPT 1½ - 11.5	111005A31
Fail safe gear replacement kit	EK6528264

Description

Blow off valve replacement kit	EK6525317
Replacement sealing plug for silencer	E6542410
Outlet pipe ND 65-100	E6536491
Outlet pipe ND 160-200	E6536613

Transport and storage

4 Transport and storage

Refer to [Figure: Correct lifting of pump](#). Transport the pump on a pallet or with a crane using both lifting eyes at the top of the pump. Never try to lift the pump on just one lifting eye.

Storage

Store the pump in a dry place, preferably at room temperature. The pump must be sealed with the supplied end caps.

Figure 2. Correct lifting of pump

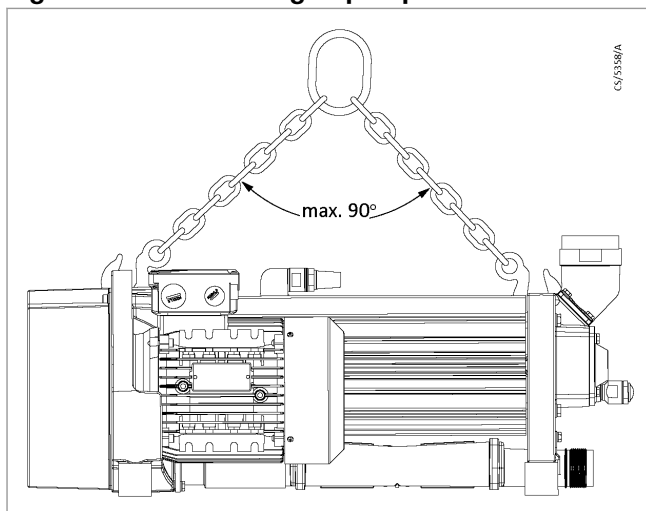

Installation

5 Installation

Figure 3. Connections and controls

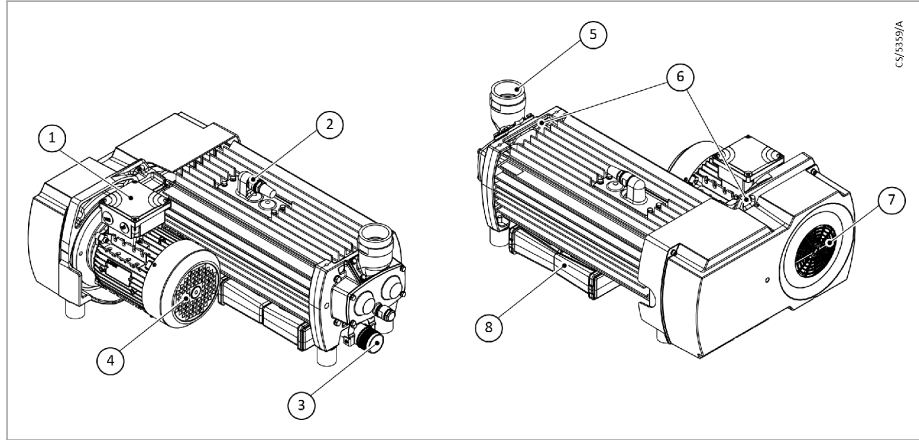

- | | |
|-----------------------|---------------------|
| 1. Motor junction box | 2. Gas ballast port |
| 3. Pump exhaust | 4. Motor fan |
| 5. Pump inlet | 6. Lifting eyes |
| 7. Pump fan | 8. Silencer |

5.1 Placement

The cooling air intake and outlets must not have a blockage to prevent insufficient cooling of the pump. Refer to [Figure: Connections and controls](#).

Make sure that there is a gap of minimum 50 mm from pump surfaces in the marked areas to assure sufficient cooling air flow.

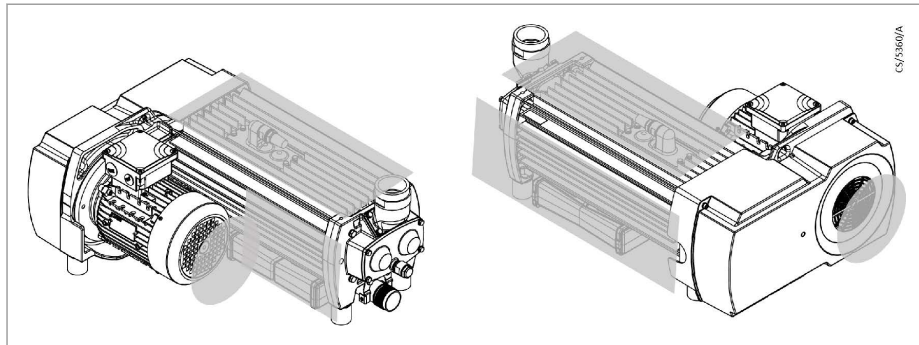

Make sure that there is enough free space around the pump for maintenance.

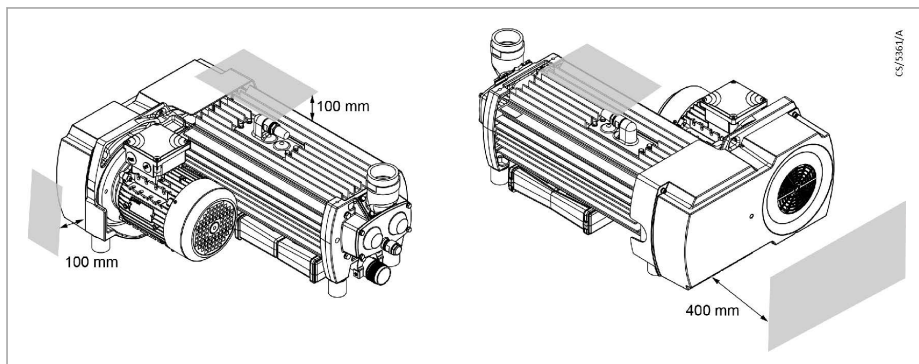

5.2 Conforming use

The pump is designed for use in food and packaging applications. The pumps are capable to handle small amounts of dust and liquids, however the use of inlet filters or liquid traps is recommended in such cases. They are not hermetically sealed and will release small amounts of pumped gases to ambient even if the exhaust port is connected to an exhaust pipework. They are suitable for pumping water steam or other vapours within the limits of the vapour tolerance. The pump can be used both continuously at a suction pressure range of 0.1 mbar to 1200 mbar as well as for cyclic pump operations within this pressure range.

5.2.1 Non-conforming use

The pump is not suited for pumping of:

- Radioactive substances
- Explosive substances
- Ignitable gas mixtures
- Pyrophoric gases
- Liquids
- Media in significant amounts condensing in the pump (Except from water)
- Solids
- Corrosive gases
- Oxidative substances with the exception of $\leq 21\%$ oxygen in the air
- Toxic gases

5.3 Connect the pump

- Remove the caps. We recommend that you retain the caps for decommissioning of the pump.
- During installation work on the intake and discharge lines do not subject flanges to any excessive stresses.

Intake side

- At the intake side, connect the pipework to the vacuum chamber.
- The intake line must be clean. Deposits in the intake line can degas and impair the vacuum. The connecting flanges must be clean and undamaged.

 **Note:**

Do not allow the ingestion of any objects (screws, welding beads, nuts, washers, pieces of wire, etc.) through the intake port of the pump.

Exhaust line



DANGER:

The operator must check, whether the pumped gases will lead to safety risks on the environment if the pump is operated without an exhaust line (for example risk of suffocation, risk of slipping due to condensing vapours, etc.).

Installation



CAUTION:

Smaller cross sections may cause an undesirable overpressure within the system. Do not start the pump with a constricted or blocked exhaust. Ensure that any valves or blocking devices in the exhaust line are open. Clogged exhaust lines will reduce the available pumping speed, increase temperature and cause overloading of the pump motor or a dangerous overpressure within the system. There is the risk of bursting. The pump can generate overpressure at the exhaust, when the discharge line is shut. The silencer has an internal burst protection plug to reduce the risk of bursting.

- Connect the exhaust line with a hose/pipework to the pump, or when operating the pump without a connected exhaust line, operate the pump only in a well ventilated room.
- The cross-section of the exhaust line must at least match the inside diameter of the connections.
- When pumping vapours, we recommend connecting a condensate separator at the exhaust. The exhaust lines should be laid so that they drop down and away, thereby preventing condensate from flowing back into the pump.
- If there is a need for a leak tight silencer, use the outlet pipe accessory
 - E6536491 for ND65 - 100
 - E6536613 for ND160 - 200

5.4 Electrical connection

The pump is supplied with three-phase motor but without accessories for electrical connection. They must be connected with the appropriate cable, and a suitable motor protection switch.

Set the switch in accordance with the rating on the pump nameplate.

Please observe the diagram inside the motor junction box.

After connecting the motor and after every time you alter the wiring, check the direction of rotation. To do so, briefly switch on the motor and make sure that the pump fan rotates in counter-clockwise direction. If not, interchange two phases of the connection.

An arrow (sticker) indicating the correct direction of rotation is placed on the drive cover. To avoid damage to the pump or the vacuum system make sure that the inlet of the pump is not connected to a closed vacuum system when doing this test. Running the pump at full speed in the wrong direction of rotation will generate pressures up to 4.5 bar (g) at the inlet port and damage the pump, if not vented to atmosphere.

Figure 4. Arrow - direction of rotation

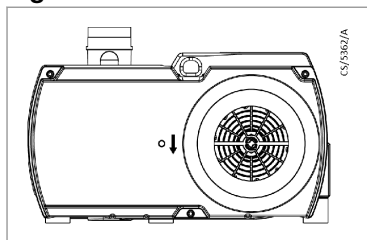

5.5 Soft starter

A motor soft starter is a device used with AC electrical motors to temporarily reduce the load and torque in the powertrain and electric current surge of

the motor during start-up. This reduces the mechanical stress on the motor and shaft, as well as the electrodynamic stresses on the attached power cables and electrical distribution network, extending the lifespan of the system. Refer to ND Soft starter manual (publication number 300963814_002_C0) for details.

5.6 Optional VFD use

If desired the pumps can be operated via an external variable frequency drive (VFD). However it is not allowed to run the pump with more than the nominal speed. A range of suitable VFDs is available as accessories. Please consult us if other types of VFDs shall be used. The permissible motor speed defined in the Technical data must be obeyed.

Please note that the pump performance and power consumption is not a linear function of motor speed.

5.7 Gas ballast

The pump is equipped with a gas ballast which feeds ambient air into the pump to dilute condensable vapours and keep the partial pressure below the condensation level. With the gas ballast in use the pump has a water vapour tolerance of 60 mbar. If the presence of condensable vapours in the pumped gases can be ruled out the gas ballast can be closed. Using the gas ballast will improve the vapour handling but reduce the vacuum performance of the pump.

5.8 Gas ballast configuration

The pump can be operated with gas ballast active (open) or closed. When changing the setup make sure that the gaskets are in good condition and that the parts are tightened correctly.

Figure 5. Gas ballast configuration

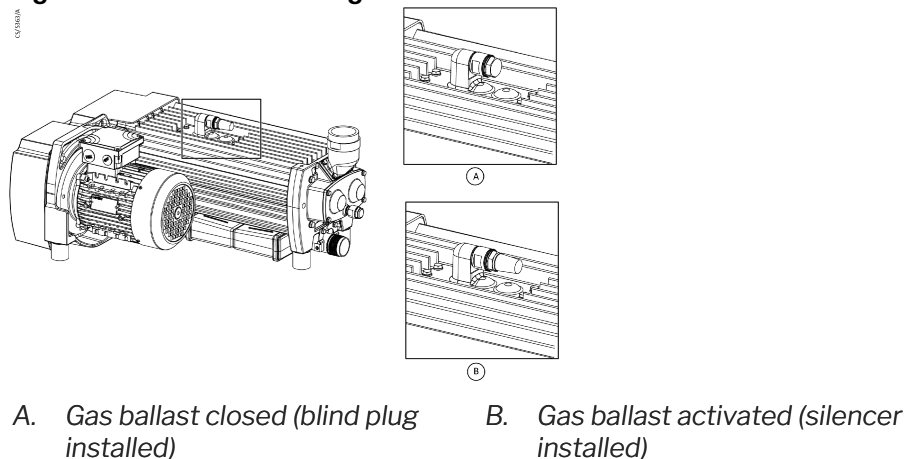

Operation

6 Operation

Start the pump by applying the supply voltage. The pump can be started up to 20 times per hour.



WARNING:

Connect the pump to an exhaust gas pipework if other gases than clean air are pumped. The exhaust of the pump must not be blocked or constricted. Never operate the pump with the seal-off stoppers in place blanking off the exhaust port.

6.1 Switching off

Switch off the pump by disconnecting from the mains voltage.

If condensable vapours have been conveyed, operate the pump for 30 minutes with closed process valve and open gas-ballast before switching off in order to evaporate the residual condensate.

The pump will run down for several seconds. Due to the design, the vacuum system is then vented through the pump, if no valve is closed between the pump and the vacuum system. In this case, the pump runs backwards until the pressure is equalized. In case of vacuum chambers exceeding a defined volume a valve must be closed before switching off the pump to avoid over-speeding of the pump and contamination of the vacuum system with dust streaming back from the exhaust pipework.

The maximum chamber sizes to be vented through the pump are:

NOVADRY ND 65: 500 L

NOVADRY ND 100: 800 L

NOVADRY ND 160-200: 1000 L

The ventilation process may take several minutes, depending on the size of the container. Wait for the pressure equalization before opening the vacuum system or disconnecting the pump from the vacuum system.

In order to avoid back-venting of the vacuum chamber close the inlet of the pump with a valve before switching off. A suitable inlet non return valve is available as optional accessory.

Maintenance

7 Maintenance

7.1 Maintenance schedule

The maintenance for the pump includes the following:

1. Belt change
2. Pump overhaul

The belt change can be done by the user of the pump.(See instructions in Pump timing belt change).

The pump overhaul requires special equipments and must be done by our service engineer only.

Maintenance	Interval (operation hours)	
	Ambient temperature: 0 °C-30 °C	Ambient temperature: 30 °C-40 °C
Belt change	6,000 hours or 25,000 start cycles	4,800 hours or 25,000 start cycles
Overhaul	25,000 hours	20,000 hours
Blow off valve inspection (applications which form deposits only)	6,000 hours	4,800 hours

7.2 Tools required for maintenance

Figure 6. Tools required for maintenance

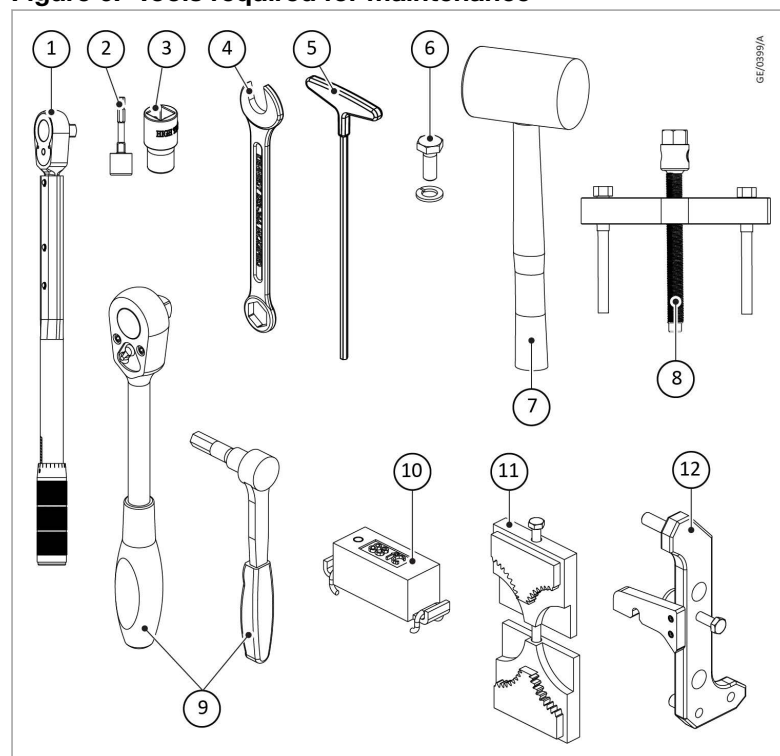

Maintenance

Sr No.	Description	Quantity
1	Torque wrench	1
2	Allen key socket No.6	1
3	Socket wrench insert 22	1
4	Wrench 12	1
5	Allen key T handle 5	1
6	M8 hex screw	1
7	Mallet	1
8	Pulling device	1
9	Ratchet	1
Special tool kit for belt replacement (EK6530942)		
10	Tool for belt tension measurement	1
11	Equipment fail safe gear adjustment	1
12	Tool for belt tension adjustment	1

7.3 Pump timing belt change

The pump timing belt is subjected to wear and must be replaced after a defined operation period (see Maintenance schedule). The belt exchange can be either performed by us or by the pump user.

Accessories required:

- Replacement timing belt
 - 50 Hz Versions: EK6528531
 - 60 Hz Versions: EK6528533

Refer to [Tools required for maintenance](#) on page 19 for more details.

7.4 Replace the belt

CAUTION:



Obey the safety regulations. Make sure that the main power source is disconnected and all parts with electric supply are covered or closed.

Make sure that there is no pressure difference between inlet and outlet of the pump during the belt change as the pressure difference will force the pump to rotate. If this can not be ruled out disconnect the pump from the vacuum system before changing the belt.



CAUTION:

Loosening the hexagon nuts of rotors will cause severe bearing damages.

7.4.1 Disassemble drive enclosure

1. Use a 5 mm Allen key to remove the 3 screws which secure the drive cover.

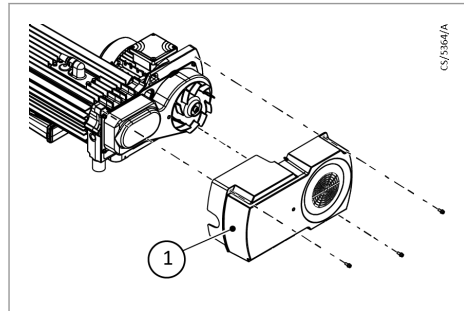

1. Drive cover

7.4.2 Disassemble rotor disc, screw and fan

1. Use a 8 mm Allen key to remove the screws, washer and rotor washer which secure the fan on the belt chamber.
2. Separate the fan from the pump.

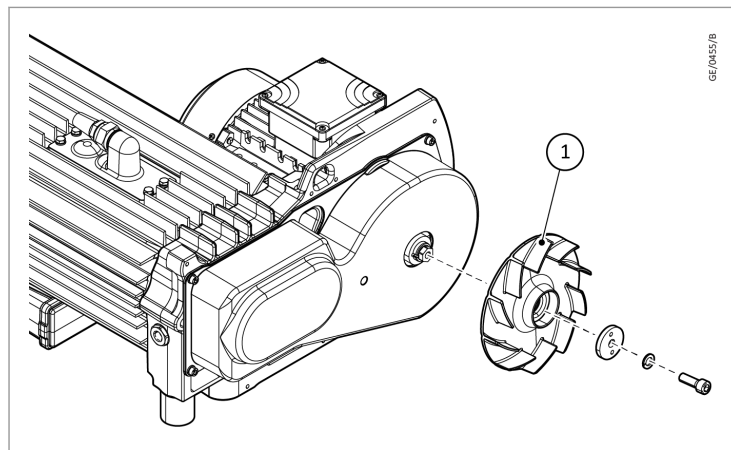

1. Fan

7.4.3 Disassemble belt chamber cover

1. Use a 5 mm Allen key to remove the 4 screws which secure the belt chamber cover.
2. Separate the belt chamber cover from the pump.

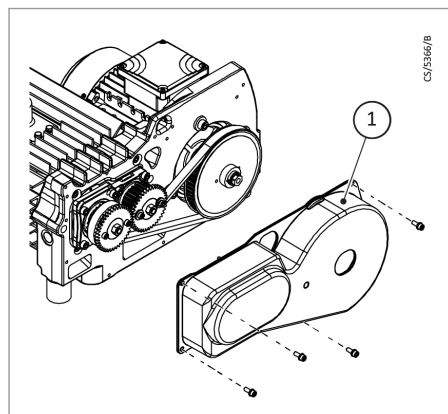

1. Belt chamber cover

Maintenance

7.4.4 Disassemble fail safe gears

1. Use the fail safe gear adjustment tool to interlock the rotors.

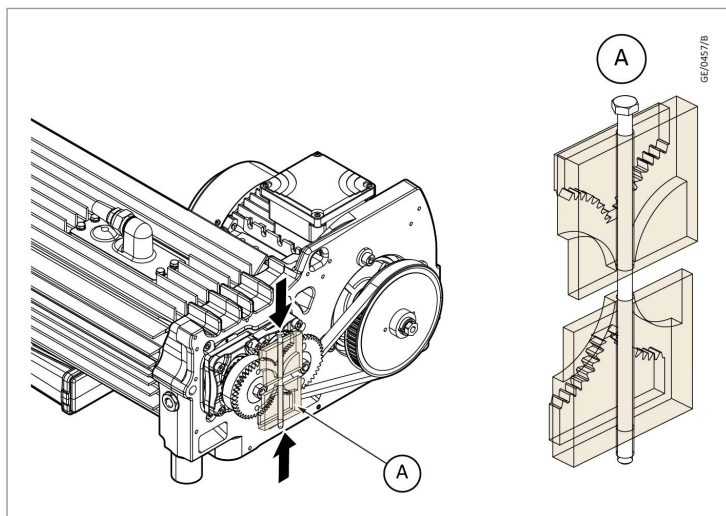

2. Loosen the 4 bolts by 1 rotation with a 5 mm Allen key and remove the bolts.

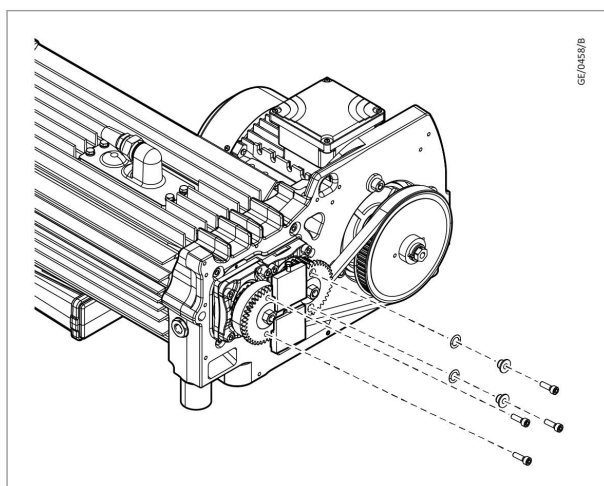

3. Remove the gear adjustment tool.

4. Remove the bushing, O-ring and fail-safe gears.

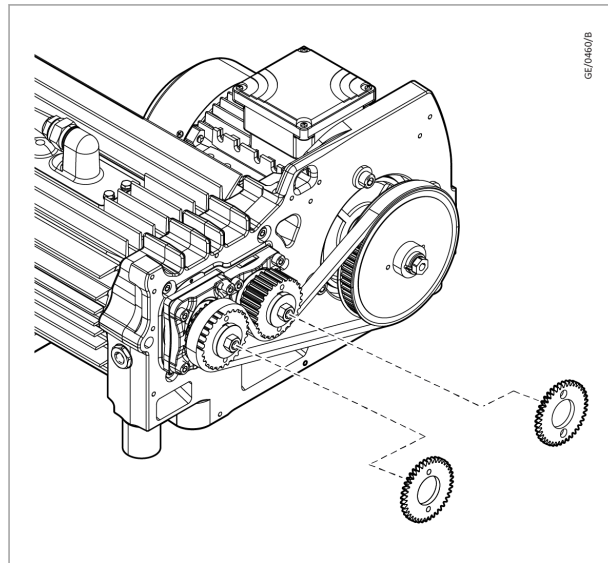

7.4.5 Disassemble belt

1. To enable belt removal, use a 8 mm Allen key to loosen the 4 screws which secure the motor and pulley to the bearing flange.

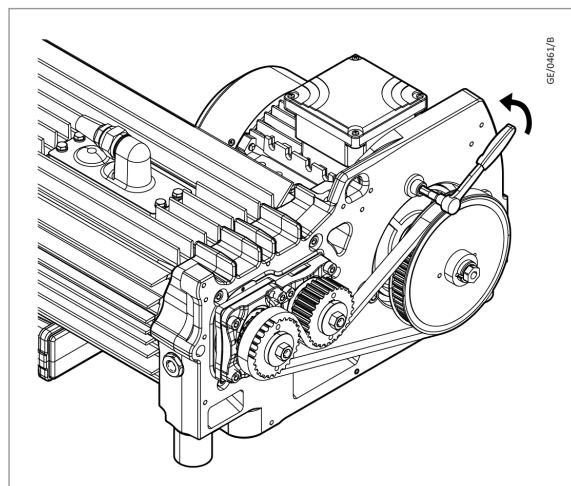

2. Push the motor towards the pump body to loosen the belt.

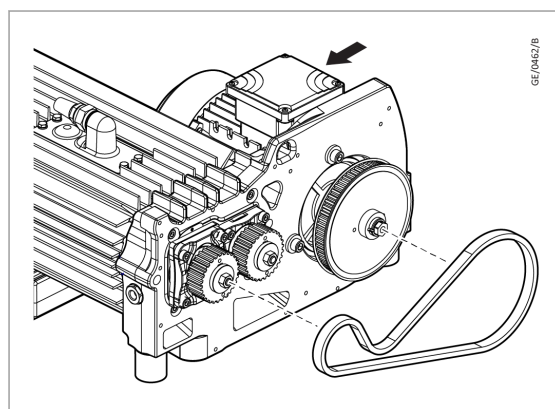

3. Take the belt out of gears and pulley.
4. Clean the gears and pulley with recommended cleaning agent.

Maintenance

5. Dispose of the old belt.

7.4.6 Assemble tooth belt

1. Place the belt on the timing gears.
2. Install the belt tighten tool and attach the VSM mini on the belt. Switch on the VSM mini.
3. Tighten the belt with a 19 mm wrench (for belt tighten tool). Tap the belt slightly and measure the frequency (Hz). Make sure that the frequency is 83 ± 5 Hz. Tap the belt 5 to 8 times to check the frequency.
4. Remove the VSM mini and the belt tightening tool.

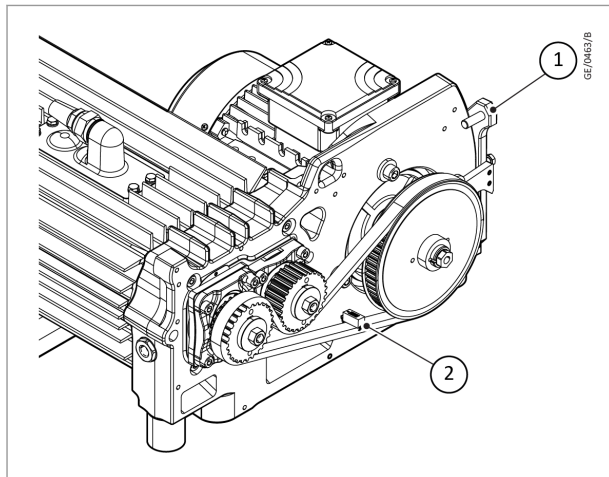

1. Belt tightening tool

2. VSM mini

7.4.7 Assemble motor screw

1. Tighten the motor cap screw with a 8 mm Allen key. Torque each screw in cross pattern to 40 Nm.
2. Rotate the pulley by hand for 5 to 8 times and make sure that the belt is tightened and running correctly.
3. Attach the VSM mini on the belt
4. Tap the belt slightly and measure the frequency (Hz).
5. Make sure that the frequency is 83 ± 5 Hz. If the belt tension is not within range, unscrew the motor cap and repeat steps in [Assemble tooth belt](#) on page 24 and steps 1-5 in this section.

6. Remove the VSM mini

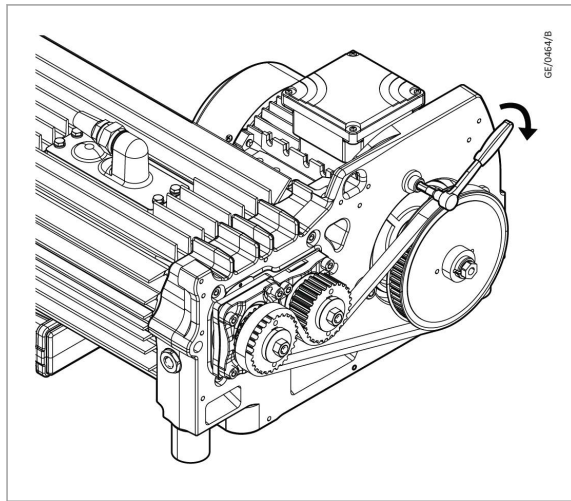

7.4.8 Assemble fail safe gear

1. Replace and assemble the fail-safe gear and all necessary parts back to original position in reverse order of disassembly.
2. Place the bolts for fastening the gears.
3. Tighten the plastic gear with 2 bolts to 10 Nm.

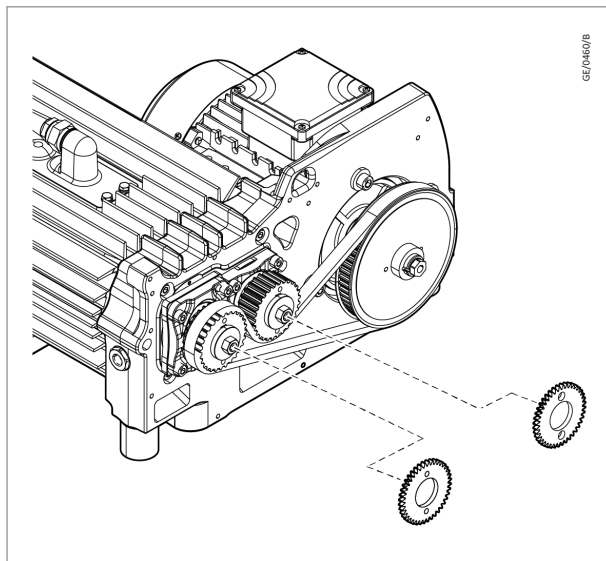

4. Rotate the motor pulley by hand for 5 to 8 revolutions in counter-clockwise direction. Do not turn clockwise, until the fail-safe gears are fastened.

Maintenance

5. Place the gear adjustment tool on gears and fasten it. Avoid clockwise rotation of belt.

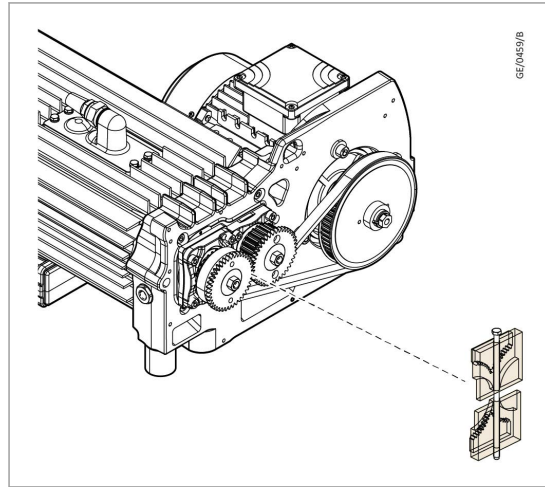

6. Tighten the steel gear with 2 bolts to 10 Nm.

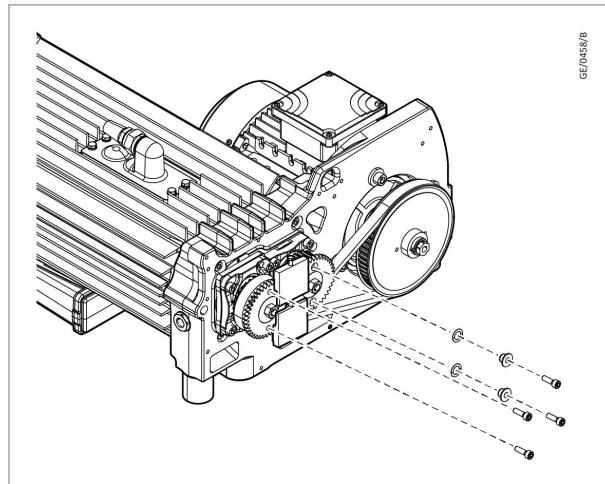

7. Remove the gear adjustment tool.
8. Rotate the motor pulley in counter clockwise direction by hand for three revolutions.
9. Make sure that the gears do not touch. If the gears touch, repeat step 5 to step 8.

7.4.9 Assemble belt chamber cover

1. Assemble the belt chamber cover onto the bearing flange with 4 cap screws with a 5 mm Allen key.
2. Tighten the cap screws by hand and torque each screw to 2.5 Nm.

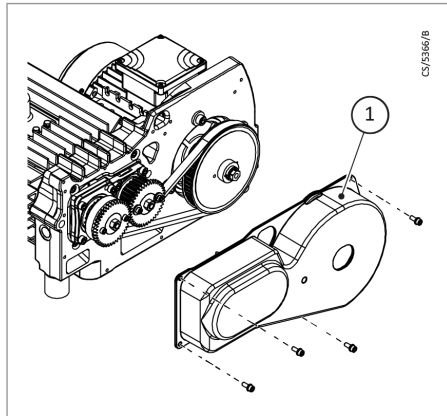

1. Belt chamber cover

7.4.10 Assemble fan

1. Assemble the fan with a 8 mm Allen key.
2. Tighten the cap screw by hand and torque screw to 20 Nm after locking the fan by spanner.

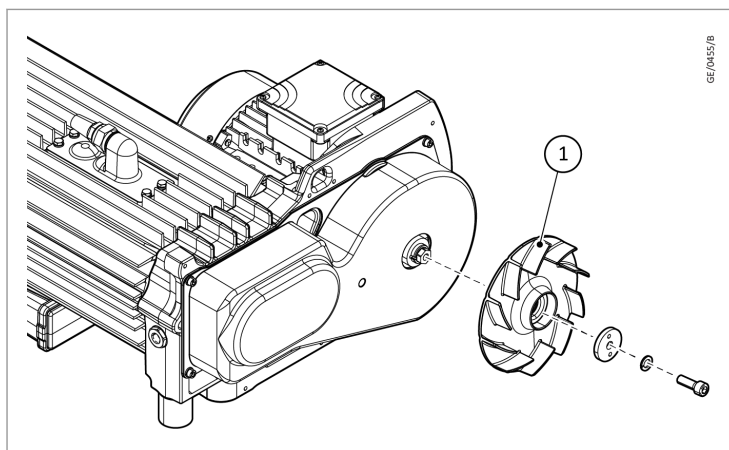

1. Fan

7.4.11 Assemble drive enclosure

1. Use a 5 mm Allen key to tighten the 3 screws which secure the drive cover.

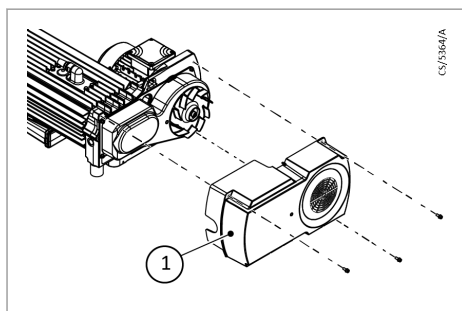

1. Drive cover

7.4.12 Electric connection

1. Open the motor terminal box.

Maintenance

2. Do the electrical connection before you install the enclosure. Refer to the pump manual for instruction.
3. Connect the cables and make sure that it is away from the hot surfaces of the pump.

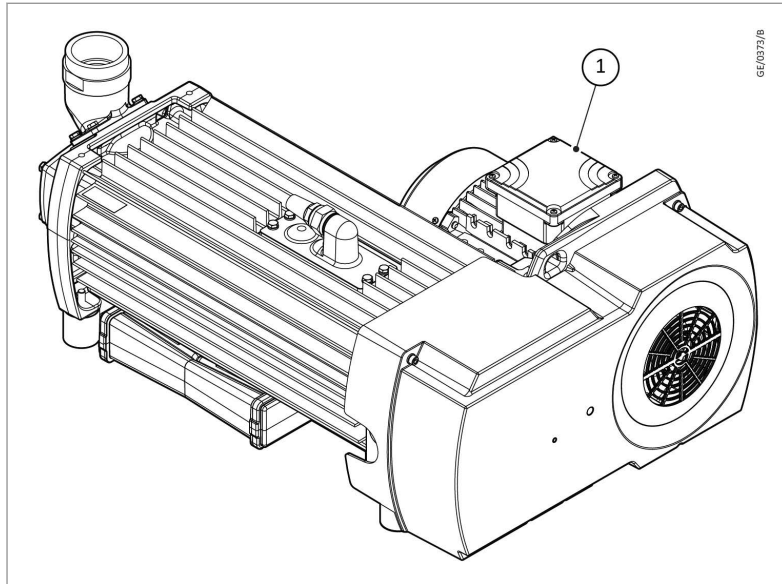

1. Motor terminal box

7.4.13 Verify motor rotation



WARNING:

Do not close the pump inlet with your hands or any other body part and avoid objects from being sucked inside the pump.

To verify the correct rotating direction of the motor, start the pump and check that

- the pump fan rotates in the same direction as the arrows on the fan protection grille.

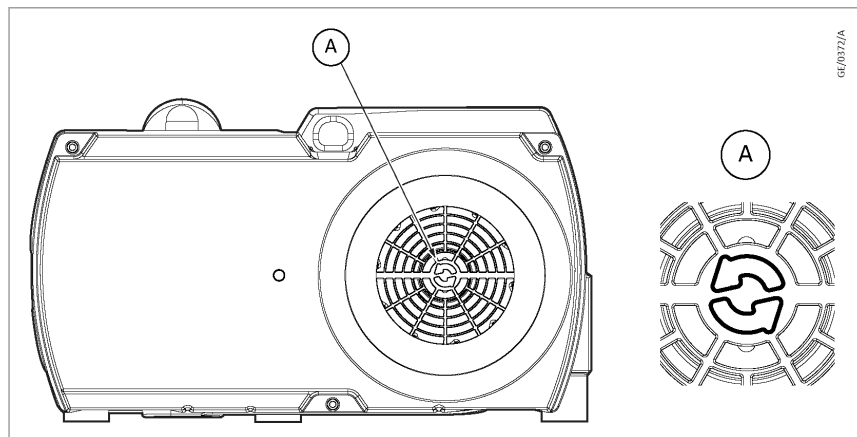

- the pump creates vacuum on the inlet port.

In case of wrong direction, swap the two phases at the motor clamping board.

7.5 Blow off valve cleaning



CAUTION:

Obey the safety regulations. Make sure that the main power source is disconnected and all parts with electric supply are covered or closed. As there will be exposure to the pumped substances, use appropriate PPE such as rubber gloves depending on the substances that are present in the process.

Accessories required to clean the blow off valve:

- Spanner: 10 mm
- Lint free cloth for cleaning
- Water or isopropanol for cleaning

To clean the blow off valve:

1. Remove the 4 x M6 screws (9) of the blow off cover (10).
2. Pull the blow off cover (10) up gently.
3. Remove the valve ball (11).
4. Check all surfaces for contamination. If required, clean with water or isopropanol.
5. Check the valve ball and all O-rings for damage or wear, replace if necessary (EK6525317).
6. Reassemble the components (a missing valve ball will destroy the pump).
7. Tighten the 4 x M10 screws with 8 Nm.

Maintenance

Figure 7. Blow Off Valve Cleaning

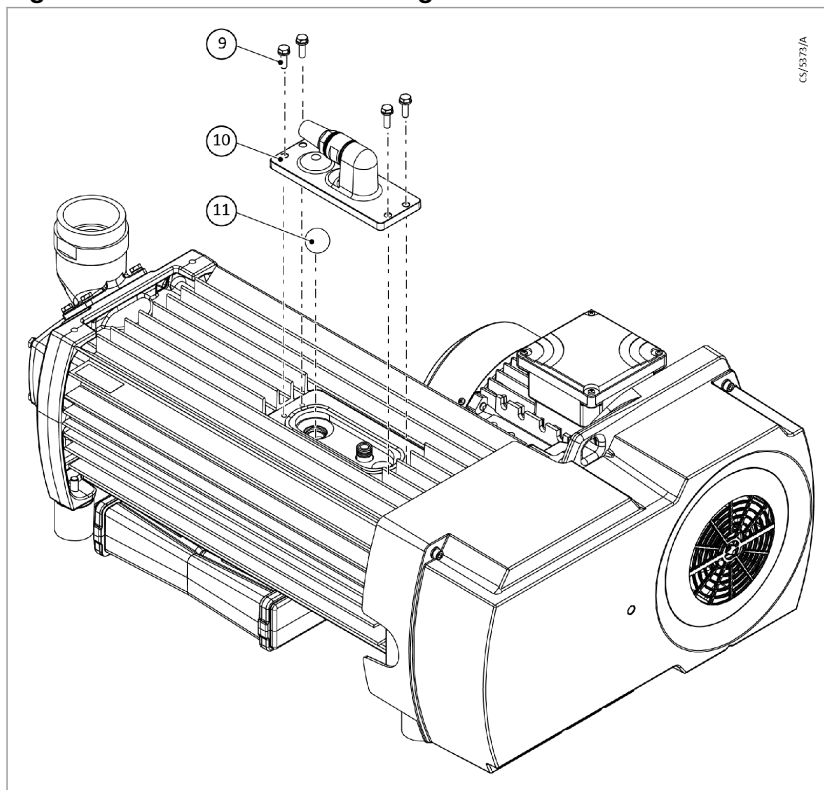

Note:

ND160/200 have two valve balls.

7.6 Replace electrical motor

7.6.1 Motor disassembly

To replace the electric motor, do the steps that follow:

1. Remove the fan cover (1).

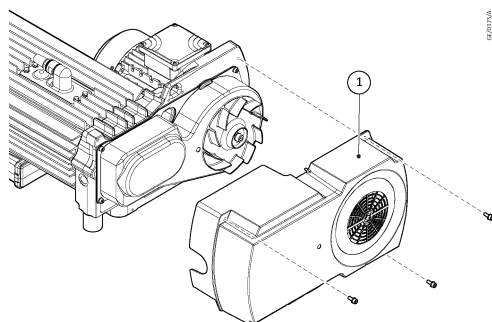

Maintenance

2. Remove the fan (2).

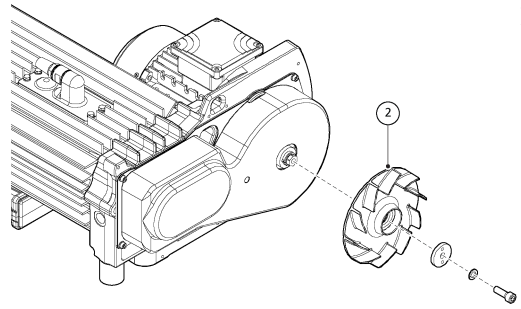

3. Remove the belt enclosure (3).

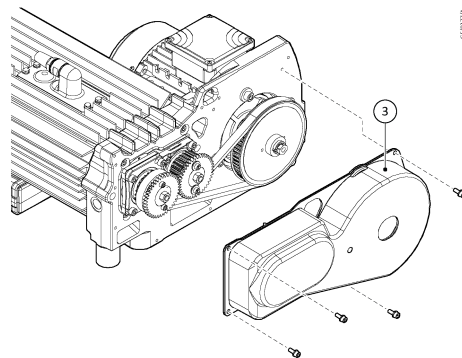

4. Block the fail safe gears with the gear adjustment tool (A).

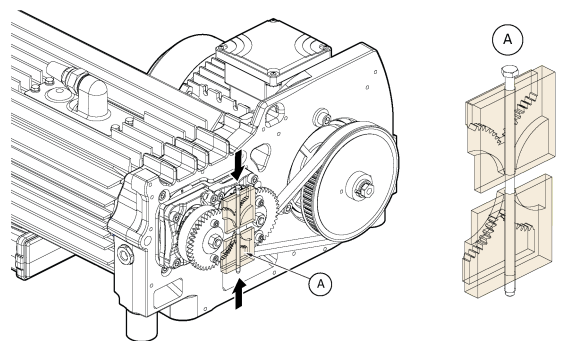

5. Loosen the centre screw.

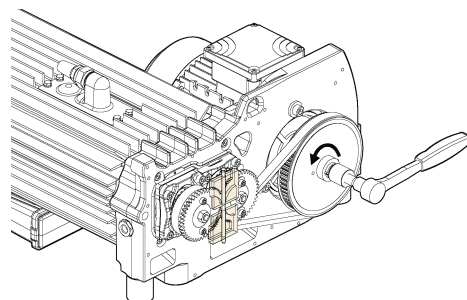

Maintenance

6. Loosen and remove the bolts of fail safe gears.

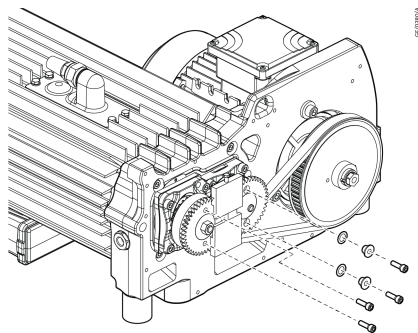

7. Remove the gear fixation tool.

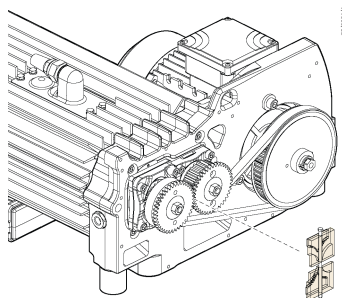

8. Remove the fail safe gears.

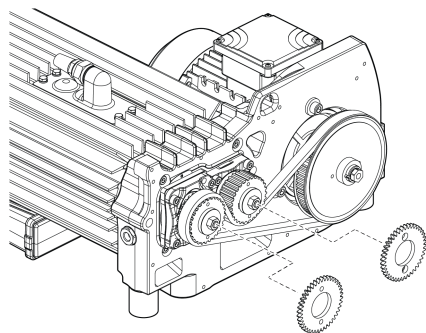

9. Remove the 4 motor screws.

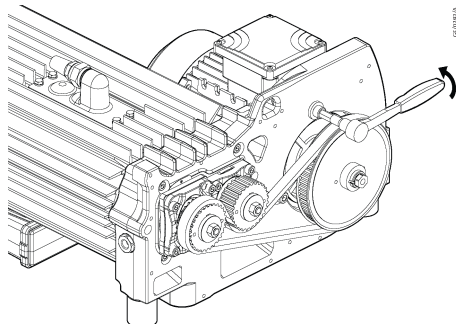

Maintenance

10. Push the motor gently and pull out the belt.

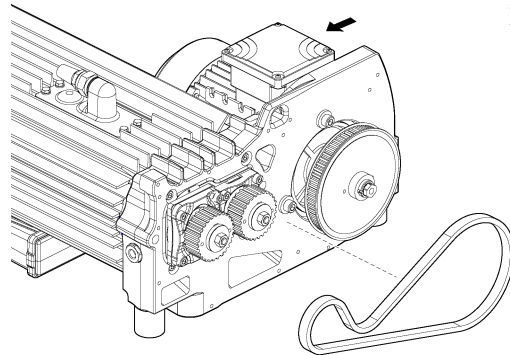

11. Remove the centre screw.

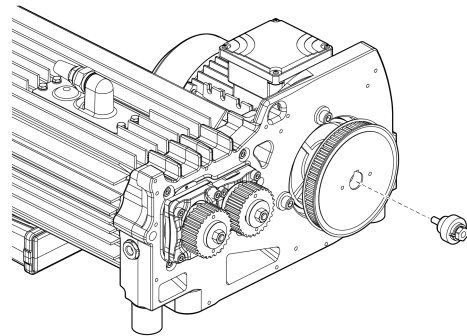

12. Install the M8 hexagonal bolt and washer.

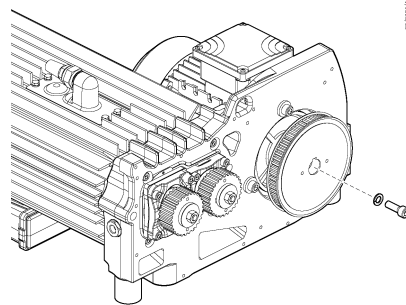

13. Install the gear puller into the middle of the pulley.

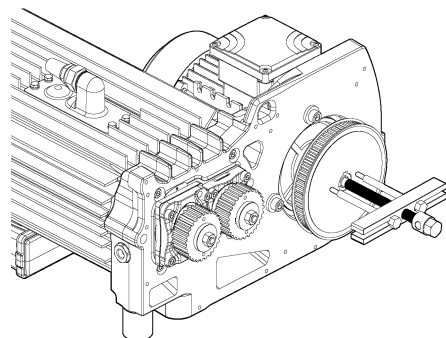

Maintenance

14. Remove the pulley with the gear puller tool.

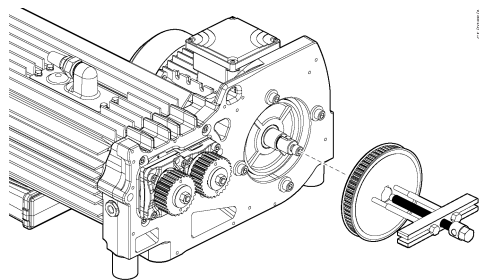

15. Unscrew the 4 motor screws.

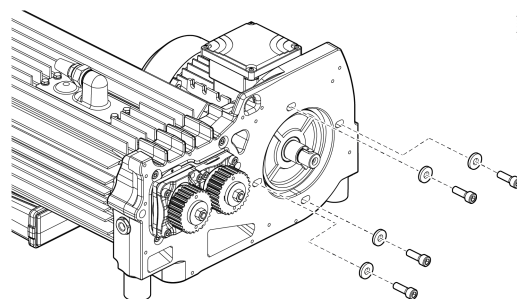

16. Remove the motor.

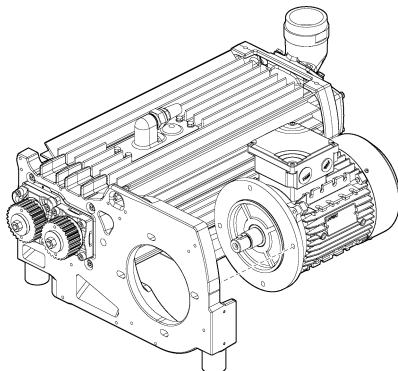

7.6.2 Motor assembly

1. Place the new motor for installation.

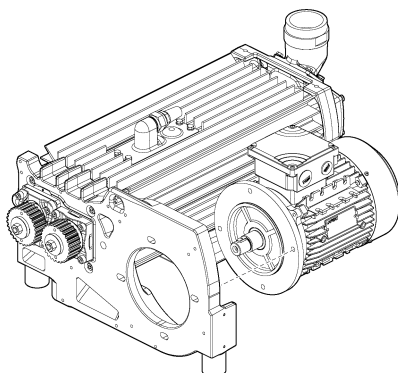

Maintenance

2. Install the 4 motor screws and hand tighten.

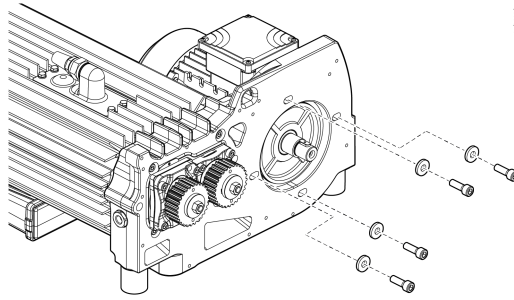

3. Install the pulley to the motor.

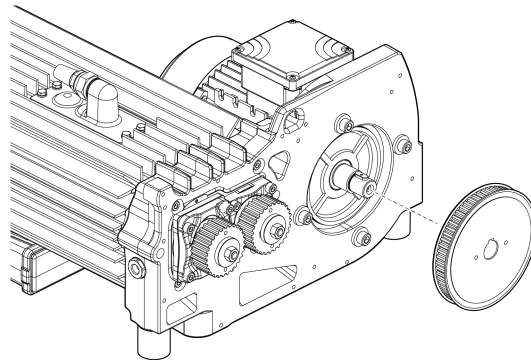

4. Make sure that the key (1) and keyway are aligned correctly.

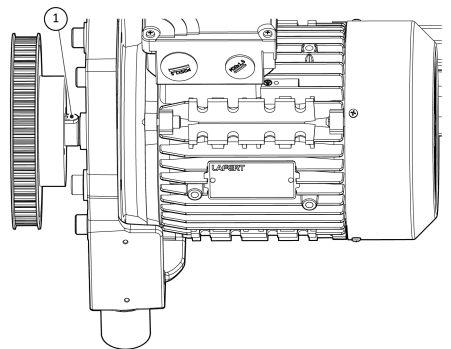

5. Tap the pulley with a mallet gently to push the pulley.

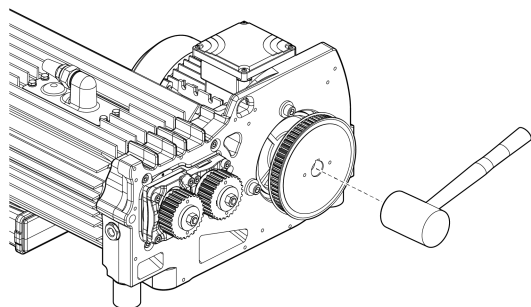

Maintenance

6. Insert the centre screw and hand tighten.

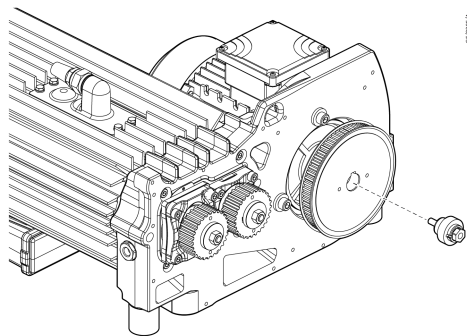

7. Install the belt gears.

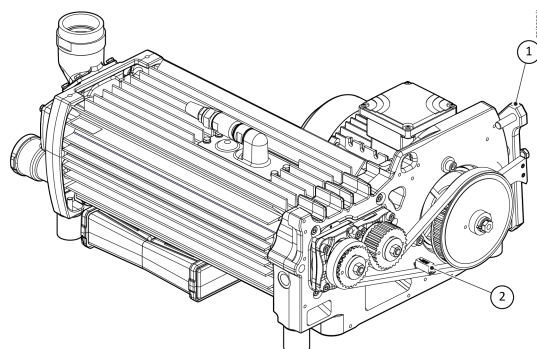

8. Tighten the motor screws.

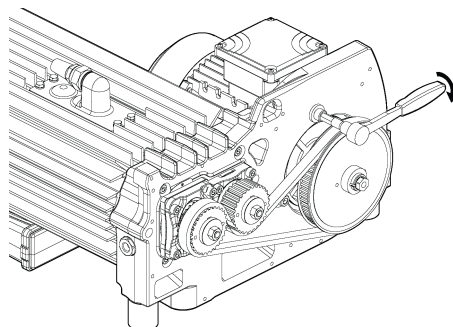

9. Replace and assemble the fail-safe gear.

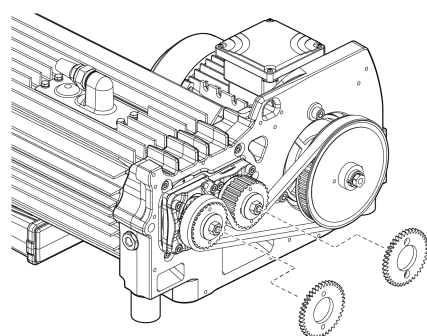

Maintenance

10. Install the gear adjustment tool on the fail safe gears.

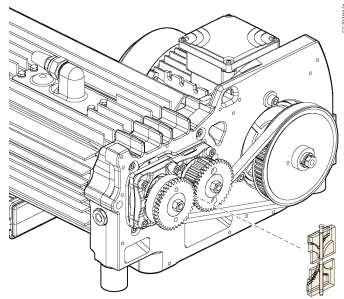

11. Assemble the fail safe gears bolts.

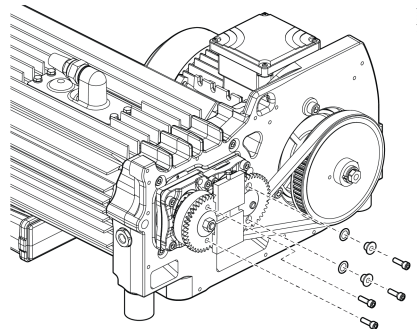

12. Fix the centre nut. Use a torque wrench to tighten the screw to 25 Nm.

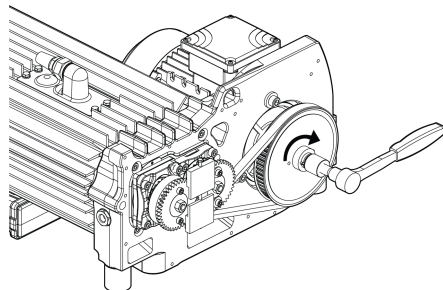

13. Install the belt enclosure (3).

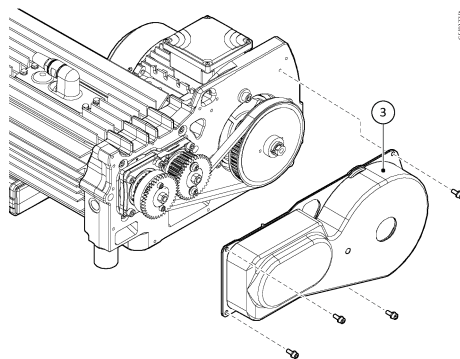

Maintenance

14. Install the fan (2).

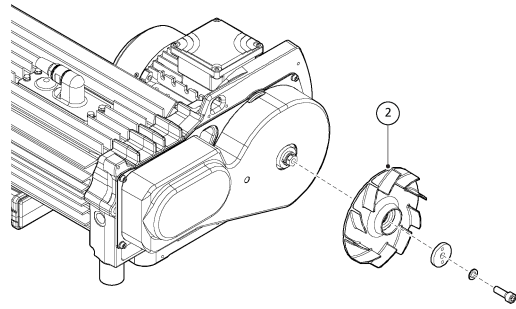

15. Install the fan cover (1).

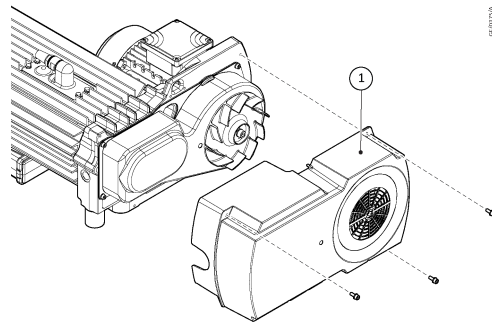

7.7 Motor part list

Table 3 Motor part list

Product name	Motor spare part no.							
	E6524957	E6537817	E6524959	E6537818	E6524971	E6537819	E6524973	E6537850
NOVADRY ND 65, 50 Hz, 200/400 V	•							
NOVADRY ND 65, 60 Hz, 230/460 V	•							
NOVADRY ND 65, 60 Hz, 200/380 V		•						
NOVADRY ND 100, 50 Hz, 200/400 V			•					
NOVADRY ND 100, 60 Hz, 230/460 V			•					
NOVADRY ND 100, 60 Hz, 200/380 V				•				
NOVADRY ND 160, 60Hz, 230/460 V					•			
NOVADRY ND 160, 60 Hz, 230/460 V					•			
NOVADRY ND 160, 60 Hz, 200/380 V						•		
NOVADRY ND 200, 50 Hz, 200/400 V							•	
NOVADRY ND 200, 60 Hz, 230/460 V							•	
NOVADRY ND 200, 60 Hz, 200/380 V								•

8 Troubleshooting

Fault Pump does not start up

Cause Wrong or loose connection at motor terminal

Remedy Check the connections

Cause Pump is blocked

Remedy Contact us

Cause Belt is broken

Remedy Contact us

Cause Motor is defective

Remedy Contact us

Cause Wrong supply voltage

Remedy Check the mains power or inverter

Fault Motor protective switch triggers

Cause Pump is blocked

Remedy Contact us

Cause Motor is defective

Remedy Contact us

Cause Wrong setting of protective switch

Remedy Adjust the setting. Refer to Technical data.

Cause Wrong direction of rotation

Remedy Check and change the direction of rotation if applicable

Cause Wrong supply voltage

Remedy Check the mains power

Cause Exhaust line is clogged

Remedy Clean the exhaust line

Fault Pump does not reach vacuum performance

Cause Inlet filter is clogged

Remedy Clean the inlet filter (if in use)

Cause Gas leak at the pump inlet

Remedy Check O-ring at inlet port or connections of accessories

Cause Wrong rotational speed

Remedy Check the mains frequency or inverter

Troubleshooting

Cause	Wrong setting of gas ballast
Remedy	Correct if applicable
Cause	Inlet seal purge is defective
Remedy	Contact us
Cause	Loose gas ballast connection
Remedy	Check tight fit of gas ballast parts
Cause	Cold pump
Remedy	Wait for 30 minutes to warm-up the pump
Cause	Wrong voltage wiring
Remedy	Check with drawing in the motor connection box
Cause	Wrong position or type of vacuum gauge
Remedy	Check pressure direct at the inlet port. We recommend type TTR or CTR 0.1 torr
Cause	Purge connection is loose
Remedy	Tighten the purge connection and check tight fit of hose

Fault Pump is noisy or has high vibration level

Cause	Pump is clogged with process deposition
Remedy	Follow the cleaning instructions
Cause	Belt is worn or defective
Remedy	Exchange the belt Contact us
Cause	Bearing is defective
Remedy	Contact us

Fault Pump does not start up

Cause	Wrong or loose connection at motor terminal
Remedy	Check the connections
Cause	Pump is blocked
Remedy	Contact us
Cause	Belt is broken
Remedy	Contact us
Cause	Motor is defective
Remedy	Contact us
Cause	Wrong supply voltage
Remedy	Check the mains power or inverter

Troubleshooting

Fault Motor protective switch triggers

Cause	Pump is blocked
Remedy	Contact us
Cause	Motor is defective
Remedy	Contact us
Cause	Wrong setting of protective switch
Remedy	Adjust the setting. Refer to Technical data.
Cause	Wrong direction of rotation
Remedy	Check and change the direction of rotation if applicable
Cause	Wrong supply voltage
Remedy	Check the mains power
Cause	Exhaust line is clogged
Remedy	Clean the exhaust line

Fault Pump does not reach vacuum performance

Cause	Inlet filter is clogged
Remedy	Clean the inlet filter (if in use)
Cause	Gas leak at the pump inlet
Remedy	Check O-ring at inlet port or connections of accessories
Cause	Wrong rotational speed
Remedy	Check the mains frequency or inverter
Cause	Wrong setting of gas ballast
Remedy	Correct if applicable
Cause	Inlet seal purge is defective
Remedy	Contact us
Cause	Loose gas ballast connection
Remedy	Check tight fit of gas ballast parts
Cause	Cold pump
Remedy	Wait for 30 minutes to warm-up the pump
Cause	Wrong voltage wiring
Remedy	Check with drawing in the motor connection box
Cause	Wrong position or type of vacuum gauge
Remedy	Check pressure direct at the inlet port. We recommend type TTR or CTR 0.1 torr
Cause	Purge connection is loose
Remedy	Tighten the purge connection and check tight fit of hose

Troubleshooting

Fault	Pump is noisy or has high vibration level
Cause	Pump is clogged with process deposition
Remedy	Follow the cleaning instructions
Cause	Belt is worn or defective
Remedy	Exchange the belt Contact us
Cause	Bearing is defective
Remedy	Contact us

9 Disposal

9.1 Waste disposal

DIRECTIVE 2012/19/EU OF THE EUROPEAN PARLIAMENT AND OF THE COUNCIL on waste electrical and electronic equipment (WEEE)

This equipment falls under the provisions of the European Directive 2012/19/EU on waste electrical and electronic appliances (WEEE) and may not be disposed as unsorted waste.



The equipment is labelled in accordance with the European Directive 2012/19/EU with the crossed-out wheellie bin symbol.

At the end of life-time of the electric and electronic equipment (EEE) it must be taken to separate collection.

For more information check with your local waste authority, customer center or distributor.

The pump may have been contaminated by the process or by environmental influences. In this case the equipment must be decontaminated in accordance with the relevant regulations. We offer this service at fixed prices. Further details are available on request.



WARNING:

Contaminated parts can be detrimental to health and environment. Before beginning with any work, first find out whether any parts are contaminated. Adhere to the relevant regulations and take the necessary precautions when handling contaminated parts.

Separate clean pumps according to their materials, and dispose of these accordingly. We offer this service. Further details are available on request.

When sending us a pump, observe the regulations given in [Leybold Service](#) on page 44.

10 Leybold Service

Whenever you send us equipment, indicate whether the equipment is contaminated or is free of substances which could pose a health hazard. If it is contaminated, specify exactly which substances are involved. You must use the form we have prepared for this purpose.

The form Declaration of Contamination for Compressors, Vacuum Pumps and Components is available on www.leybold.com-> [Downloads](#) -> [Download Documents](#).

Attach the form to each pump. This statement detailing the type of contamination is required to satisfy legal requirements and for the protection of our employees.

We will return to the sender any equipment which is not accompanied by a contamination statement.

EU Declaration of Conformity

(Translation of original Declaration of Conformity)

The manufacturer: Leybold GmbH
Bonner Strasse 498
D-50968 Köln
Germany

herewith declares that the products specified and listed below which we have placed on the market, comply with the applicable EU Directives. This declaration becomes invalid if modifications are made to the product without agreement of Leybold GmbH.

Product designation: Fore vacuum pump
Type designation: NOVADRY ND 65-200
Part numbers: 111065N..., 111100N..., 111160N..., 111200N...

The products comply to the following directives:

Machinery Directive (2006/42/EC)

The safety objectives of the Low Voltage Directive 2014/35/EU were complied with in accordance with Appendix 1 No. 1.5.1 of Machinery Directive 2006/42/EC.

Electromagnetic Compatibility (2014/30/EU)

Directive RoHS (2011/65/EU) & (2015/863/EU)

The following harmonized standards have been applied:

EN 1012-2:1996+A1:2009	Compressors and vacuum pumps - Safety requirements Part 2: Vacuum pumps
EN 60204-1:2006	Safety of machinery - Electrical equipment of machines Part1: General requirements
EN 61000-6-2:2005/AC:2005	Electromagnetic compatibility (EMC) - Part 6-2: Generic standards - Immunity for industrial environments
EN 61000-6-4:2007/A1:2011	Electromagnetic compatibility (EMC) - Part 6-4: Generic standards - Emission standard for industrial environments
EN 50581:2012	Technical documentation for the assessment of electrical and electronic products with respect to the restriction of hazardous substances

Documentation officer: Herbert Etges
T: +49(0)221 347 0
F: +49(0)221 347 1250
documentation@leybold.com

Cologne, September 12th, 2019

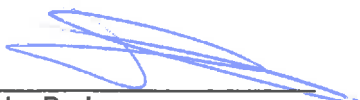

Andries Desiron
Vice President Engineering
Atlas Copco Industrial Vacuum Division

Cologne, September 12th, 2019



Axel Guddas
General Manager
Leybold GmbH

This page has been intentionally left blank.

This page has been intentionally left blank.



Pioneering products. Passionately applied.

Leybold GmbH
Bonner Strasse 498
50968 Cologne
GERMANY
+49-(0)221-347-0
info@leybold.com
www.leybold.com